

3705F DIN 6336 F CAST IRON UNMACHINED

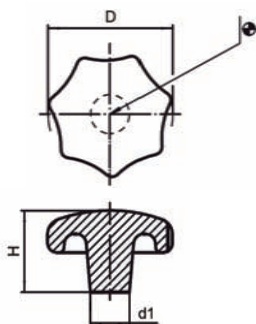

Fe: Cast iron, sandblasted.



Code	D	H	d1
370503000	32	21	12
370504000	40	26	14
370505000	50	34	18
370506000	63	42	20
370508000	80	52	25

3705C DIN 6336 C CAST IRON WITH THREADED BLIND HOLE



Female threaded blind hole.
Fe: Cast iron, sandblasted.

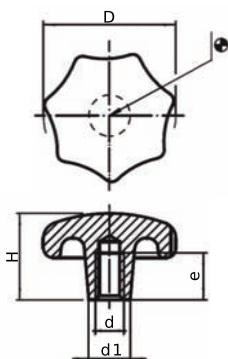

Code	D	H	d1	d	e
370500432	32	20	12	M6	12
370500440	40	25	14	M8	15
370500450	50	32	18	M10	18
370500463	63	40	20	M12	22
370500480	80	50	25	M16	28

3705E DIN 6336 E CAST IRON WITH THREADED DRILL OUT HOLE



Female thread drilled out.
Fe: Cast iron, sandblasted.

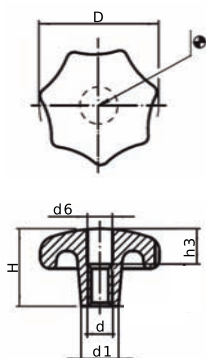

Code	D	H	d1	d6	d	h3
370500332	32	20	12	6,4	M6	10
370500340	40	25	14	8,4	M8	12
370500350	50	32	18	10,5	M10	16
370500363	63	40	20	13,0	M12	20
370500380	80	50	25	17,0	M16	30

3707F DIN 6335 F CAST IRON UNMACHINED



Fe: Cast iron, sandblasted.

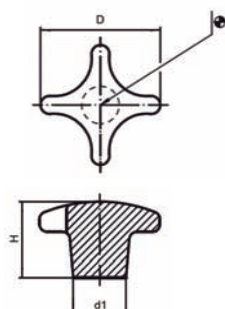

Code	D	H	d1
370703000	32	21	12
370704000	40	26	14
370705000	50	34	18
370706000	63	42	20
370708000	80	52	25
370710000	100	65	32

3707C DIN 6335 C CAST IRON WITH THREADED HOLE



Female threaded blind hole.
Fe: Cast iron, sandblasted.

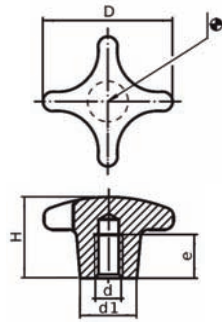

Code	D	H	d1	d	e
370700432	32	20	12	M6	12
370700440	40	25	14	M8	15
370700450	50	32	18	M10	18
370700463	63	40	20	M12	22
370700480	80	50	25	M16	28
370700490	100	63	32	M20	36

3707E DIN 6335 E CAST IRON WITH THREADED DRILL OUT HOLE



Female thread drilled out.
Fe: Cast iron, sandblasted.

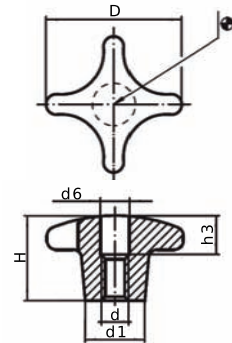

Code	D	H	d1	d6	d	h3
370700332	32	20	12	6,4	M6	10
370700340	40	25	14	8,4	M8	12
370700350	50	32	18	10,5	M10	16
370700363	63	40	20	13,0	M12	20
370700380	80	50	25	17,0	M16	30
370700390	100	63	32	21,0	M20	38

3707F INOX DIN 6335 STAINLESS STEEL UNMACHINED



SS: Stainless Steel 1.4305,
dull blasted.

INOX
Stainless
Steel

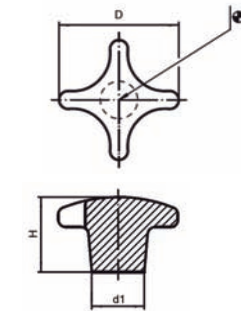

Code	D	H	d1
370710032	32	21	12
370710040	40	26	14
370710050	50	34	18
370710053	63	42	20

3707C INOX DIN 6335 STAINLESS STEEL WITH THREADED HOLE



Female threaded blind hole.
SS: Stainless Steel 1.4305,
dull blasted

INOX
Stainless
Steel

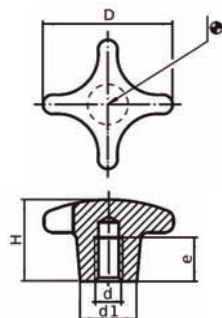

Code	D	H	d1	d	e
370710432	32	20	12	M6	12
370710440	40	25	14	M8	15
370710450	50	32	18	M10	18
370710463	63	40	20	M12	22

**3707E
INOX**

DIN 6335 STAINLESS STEEL WITH THREADED DRILL OUT HOLE



INOX
Stainless
Steel

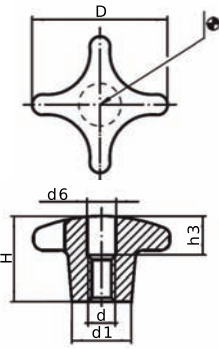

Code	D	H	d1	d6	d	h3
370710332	32	20	12	6,4	M6	10
370710340	40	25	14	8,4	M8	12
370710350	50	32	18	10,5	M10	16
370710363	63	40	20	13,0	M12	20

Female thread drilled out.
SS: Stainless Steel 1.4305,
dull blasted.

3709E

DIN 6303 E STEEL WITH THREADED DRILL OUT HOLE

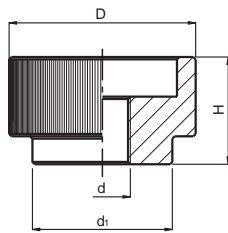

Code	D	H	d	d1	Finish
370920105	20	12	M5	14	Blackened
370924106	24	14	M6	16	Blackened
370930108	30	17	M8	20	Blackened
370936110	36	20	M10	28	Blackened
370940112	40	24	M12	32	Blackened

Female thread, drilled out.
Fe: Free cutting steel, blackened.

3711C

SOLID SS KNOB C WITH THREADED HOLE



INOX
Stainless
Steel

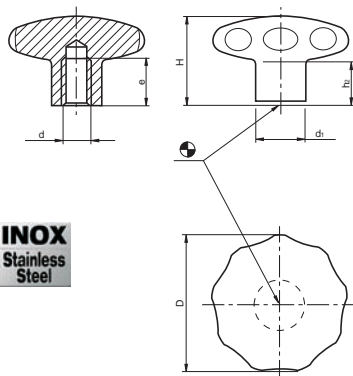

Code	D	H	d1	e	d	h2	Finish
371100645	40	30,5	18	12	M6	15	Dull Blasted
371100646	40	30,5	18	12	M8	15	Dull Blasted
371100655	50	34,0	21	15	M8	17	Dull Blasted
371100656	50	34,0	21	15	M10	17	Dull Blasted
371100665	60	39,0	25	18	M10	18	Dull Blasted
371100666	60	39,0	25	18	M12	18	Dull Blasted

Female thread.
Inox: Stainless Steel 1.4305.
For all applications having high
hygienic requirements.

3711E SOLID SS KNOB E WITH THREADED DRILL OUT HOLE

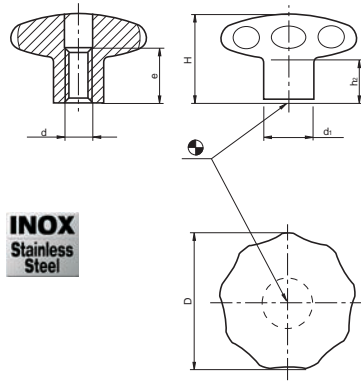
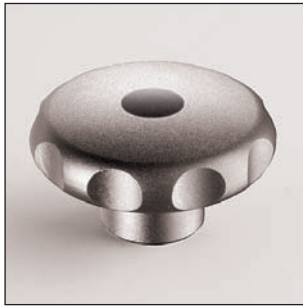

INOX
Stainless Steel

Female thread, drilled-out.
INOX: Stainless steel 1.4305.
For all applications having high hygienic requirements.

Code	D	H	d1	e	d	h2	Finish
371100644	40	30,5	18	13	M8	15	Dull Blasted
371100654	50	34,0	21	16	M10	17	Dull Blasted
371100664	60	39,0	25	20	M12	18	Dull Blasted

3711G SOLID SS KNOB G WITH SMOOTH HOLE

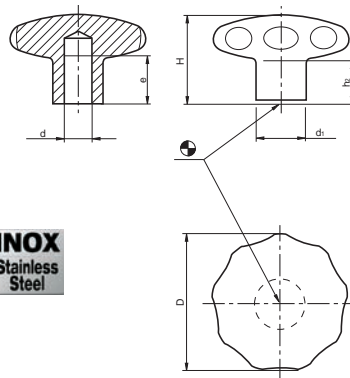

INOX
Stainless Steel

With smooth blind hole.
INOX: Stainless steel 1.4305.
For all applications having high hygienic requirements.

Code	D	H	d1	e	d	h2	Finish
371100643	40	30,5	18	12	8	15	Dull Blasted
371100653	50	34,0	21	15	10	17	Dull Blasted
371100663	60	39,0	25	18	12	18	Dull Blasted

3711C SS STAR KNOB C WITH THREADED HOLE

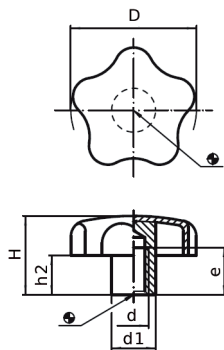

INOX
Stainless Steel

Female thread.
INOX: Stainless steel 1.4301.
Sheet-iron drawn with hub welded.

Code	D	H	d1	d	e	h2	Finish
371100440	40	25	14	M8	15	12,5	Dull Blasted
371100450	50	32	18	M10	18	17,5	Dull Blasted
371100460	60	40	20	M12	22	21,0	Dull Blasted

3711G SS STAR KNOB G WITH SMOOTH HOLE

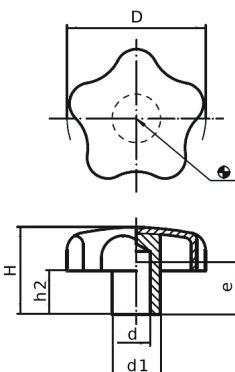

INOX
Stainless Steel

With smooth blind hole (d H7).
Dimension e shows min. length.
INOX: Stainless steel 1.4301.
Sheet-iron drawn with hub welded.

Code	D	H	d1	d	e	h2	Finish
371100240	40	25	14	8	15	12,5	Dull Blasted
371100250	50	32	18	10	18	17,5	Dull Blasted
371100260	60	40	20	12	22	21,0	Dull Blasted

3711T SS STAR KNOB T WITH THREADED STUD



INOX
Stainless
Steel

Threaded stud.
INOX: Stainless steel 1.4301.
Sheet-iron drawn with hub welded.

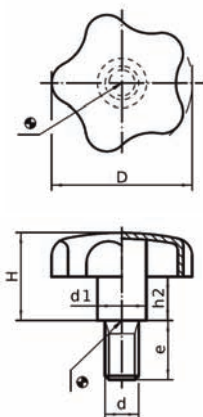

Code	D	H	d1	d	e	h2	Finish
371100140	40	24	14	M8	20	12,0	Dull Blasted
371100144	40	24	14	M8	40	12,0	Dull Blasted
371100150	50	30	18	M10	20	16,5	Dull Blasted
371100154	50	30	18	M10	40	16,5	Dull Blasted
371100160	60	37,5	20	M12	30	20,0	Dull Blasted
371100164	60	37,5	20	M12	50	20,0	Dull Blasted

3749C DIN 6335 C ALUMINIUM WITH THREADED HOLE



Female thread.
AL: Aluminium, polished.

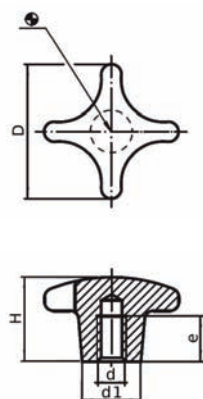

Code	D	H	d1	d	e	Finish
374900840	40	25	14	M8	15	Polished
374900850	50	32	18	M10	18	Polished
374900863	63	40	20	M12	22	Polished
374900880	80	50	25	M16	28	Polished

3749E DIN 6335 E ALUMINIUM WITH THREADED DRILL OUT HOLE



Female thread drilled out.
AL: Aluminium, polished.

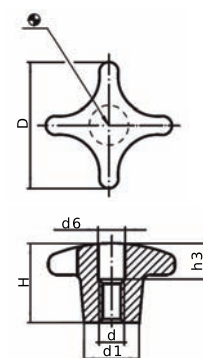

Code	D	H	d1	d	h3	d6	Finish
374900740	40	25	14	M8	12	8,4	Polished
374900750	50	32	18	M10	16	10,5	Polished
374900763	63	40	20	M12	20	13,0	Polished
374900780	80	50	25	M16	30	17,0	Polished

3323G DIN 6335 G ALUMINIUM WITH SMOOTH HOLE



With smooth blind hole.
AL: Aluminium, polished.

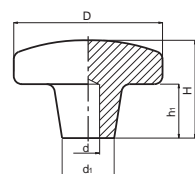

Code	D	H	d1	h1	d	Finish
332304101	40	26	14	13	6±1	Polished
332305101	50	34	18	17	6±1	Polished
332306101	63	42	20	23	6±1	Polished
332308101	80	52	25	29	6±1	Polished

3323F DIN 6335 F ALUMINIUM UNMACHINED, NOT POLISHED

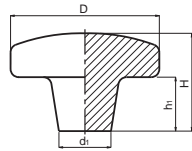

Code	D	H	d1	h1	Finish
332304201	40	25	14	12	Not Polished
332305201	50	32	18	17	Not Polished
332306201	63	40	20	23	Not Polished
332308201	80	50	25	28	Not Polished

AL: Aluminium, not polished.

3753C DIN 6336 C ALUMINIUM WITH THREADED HOLE, POLISHED

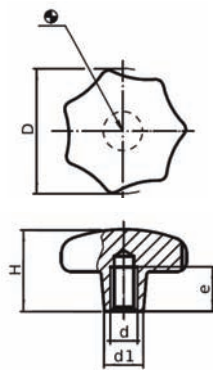

Code	D	H	d1	d	e	Finish
375300840	40	25	14	M8	15	Polished
375300850	50	32	18	M10	18	Polished
375300863	63	40	20	M12	22	Polished
375300880	80	50	25	M16	28	Polished

Female threaded blind hole.
AL: Aluminium, polished.

3753D DIN 6336 D ALUMINIUM WITH THREADED DRILL OUT HOLE

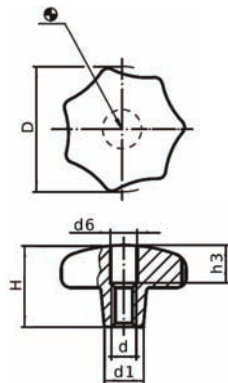

Code	D	H	d1	d6	d	h3	Finish
375300740	40	25	14	8	M8	15	Polished
375300750	50	32	18	10	M10	18	Polished
375300763	63	40	20	13	M12	22	Polished
375300780	80	50	25	17	M16	28	Polished

Female thread drilled out.
AL: Aluminium, polished.

3320G DIN 6336 G ALUMINIUM UNMACHINED, POLISHED

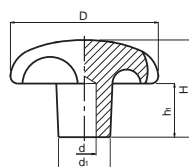

Code	D	H	d1	h1	d	Finish
332004101	40	25	14	12	6±1	Polished
332005101	50	32	18	16	6±1	Polished
332006101	63	40	20	20	6±1	Polished
332008101	80	50	25	25	6±1	Polished

AL: Aluminium, polished.

3320F DIN 6336 F ALUMINIUM UNMACHINED, NOT POLISHED

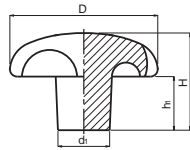

Code	D	H	d1	h1	Finish
332004201	40	25	14	13	Not Polished
332005201	50	32	18	16	Not Polished
332006201	63	40	20	20	Not Polished
332008201	80	50	25	24	Not Polished

AL:Aluminium, not polished.

3766T DIN 653 FLAT KNURLED THUMB SCREW

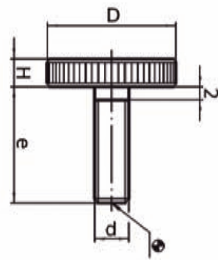

Code	D	H	d	e
376600073	12	2.5	M3	8
376600077	12	2.5	M3	16
376600093	16	3.5	M4	10
376600096	16	3.5	M4	16
376600113	20	4	M5	12
376600117	20	4	M5	20
376600134	24	5	M6	16
376600138	24	5	M6	25
376600154	30	6	M8	20
376600158	30	6	M8	30
376600174	36	8	M10	25
376600180	36	8	M10	40

Threaded stud.
Fe: Steel quality 5,8 blackened.

3766T SS DIN 653 FLAT KNURLED THUMB SCREW



INOX
Stainless
Steel

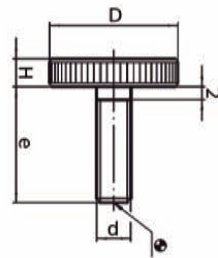

Code	D	H	d	e
376600293	16	3.5	M4	10
376600296	16	3.5	M4	16
376600313	20	4	M5	12
376600317	20	4	M5	20
376600334	24	5	M6	16
376600338	24	5	M6	25
376600354	30	6	M8	20
376600358	30	6	M8	30
376600374	36	8	M10	25
376600380	36	8	M10	40

Threaded stud.
INOX: Stainless Steel 1.4305,
dull blasted.

3768D DIN 467 FLAT KNURLED NUT

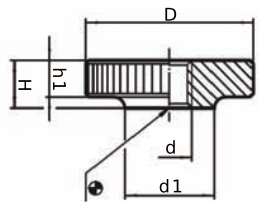

Code	D	H	d	d1	h1
376800030	12	3	M3	6	2.5
376800040	16	4	M4	8	3.5
376800050	20	5	M5	10	4
376800060	24	6	M6	12	5
376800080	30	8	M8	16	6
376800100	36	10	M10	20	8
376800120	40	12	M12	22	10

Female thread drilled out.
Fe: Steel quality 5 blackened.
DIN standards do not include
the item 376800120.

3768D SS DIN 467 FLAT KNURLED NUT

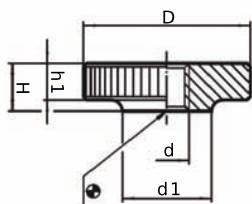

INOX
Stainless
Steel

Female thread drilled out.
INOX: Stainless Steel 1.4305,
dull blasted.

Code	D	H	d	d1	h1
376800230	12	3	M3	6	2.5
376800240	16	4	M4	8	3.5
376800250	20	5	M5	10	4
376800260	24	6	M6	12	5
376800280	30	8	M8	16	6
376800300	36	10	M10	20	8

3769T DIN 464 KNURLED THUMB SCREW

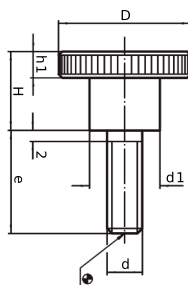

Threaded stud.
Fe: Steel quality 5,8 blackened.

Code	D	H	d	e	h1	d1
376900076	12	7.5	M3	10	2.5	6
376900079	12	7.5	M3	16	2.5	6
376900095	16	9.5	M4	10	3.5	8
376900098	16	9.5	M4	16	3.5	8
376900115	20	11.5	M5	12	4	10
376900119	20	11.5	M5	20	4	10
376900136	24	15	M6	16	5	12
376900142	24	15	M6	30	5	12
376900154	30	18	M8	16	6	16
376900160	30	18	M8	30	6	16
376900175	36	23	M10	25	8	20
376900181	36	23	M10	40	8	20

3769T SS DIN 464 KNURLED THUMB SCREW



INOX
Stainless
Steel

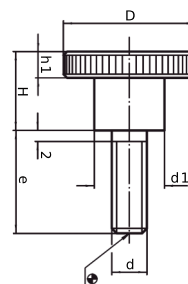

Threaded stud.
INOX: Stainless Steel 1.4305, dull blasted.

Code	D	H	d	e	h1	d1
376900295	16	9.5	M4	10	3.5	8
376900298	16	9.5	M4	16	3.5	8
376900315	20	11.5	M5	12	4	10
376900319	20	11.5	M5	20	4	10
376900336	24	15	M6	16	5	12
376900342	24	15	M6	30	5	12
376900354	30	18	M8	16	6	16
376900360	30	18	M8	30	6	16

3772D DIN 466 KNURLED NUT

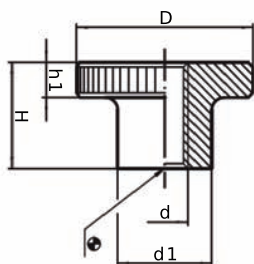
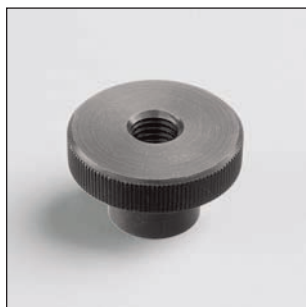

Female thread drilled out.
Fe: Steel quality 5 blackened.
DIN standards do not include
the item 377200120.

Code	D	H	d	d1	h1
377200030	12	7.5	M3	6	2.5
377200040	16	9.5	M4	8	3.5
377200050	20	11.5	M5	10	4
377200060	24	15	M6	12	5
377200080	30	18	M8	16	6
377200100	36	23	M10	20	8
377200120	40	25	M12	22	10

3772D SS DIN 466 KNURLED NUT

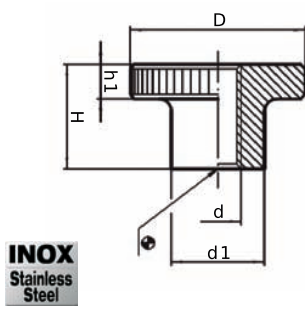

INOX
Stainless
Steel

Code	D	H	d	d1	h1
377200240	16	9.5	M4	8	3.5
377200250	20	11.5	M5	10	4
377200260	24	15	M6	12	5
377200280	30	18	M8	16	6
377200300	36	23	M10	20	8

Female thread drilled out.
INOX: Stainless Steel 1.4305, dull blasted.

3882 KNOB TK STEEL, KNURLED

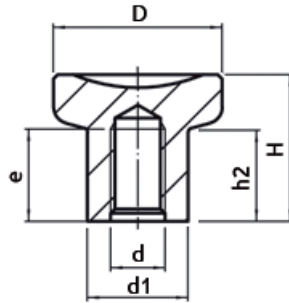

Code	D	H	h2	d	e	d1
388200023	21	18	10,5	M5	10	12,5
388200025	25	22,5	14	M6	12	14,5
388200028	31	27	17	M8	15	18,5
388200029	31	27	17	M10	17	18,5

Female threaded blind hole.
Fe: Steel, blackened.

3882 KNOB TK STAINLESS STEEL

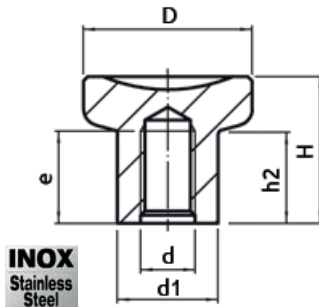

INOX
Stainless
Steel

Code	D	H	h2	d	e	d1
388200103	21	18	10,5	M5	10	12,5
388200105	25	22,5	14	M6	12	14,5
388200108	31	27	17	M8	15	18,5
388200109	31	27	17	M10	17	18,5

Female threaded blind hole.
SS: Stainless Steel 1.4305, dull blasted.