

SPIS

F **1** Tuleje Taper Bush 

F **2 - 15** Elementy blokujące - pierścienie rozprężno-zaciskowe 



TULEJE TAPER BUSH

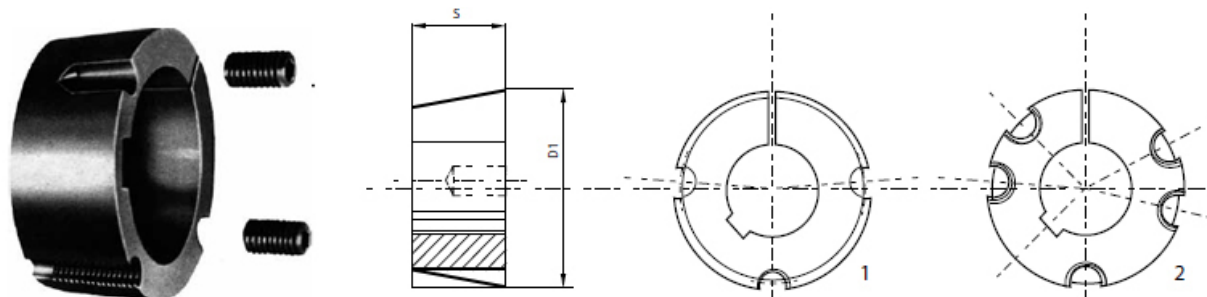

Żeliwo EN-GJL-250 UNI EN 1561

Rozmiary otworów dostępne z magazynu											Przykład: Symbol Otwór w mm Ø 14 = 1615014																
TYP	KOD	BORE (ISO E 8)										PRZENO-SZONY MOMENT OBROTOWY N•m	ŚRUBY	D1	TYP	S	MASA										
1008	1008...	9	10	11	12	14	16	18	19	20	22	24	25	136	1/4" x 1/2"	35,0	1	22,3	0,16								
1108	1108...	9	10	11	12	14	16	18	19	20	22	24	25	28*	147	1/4" x 1/2"	38,0	1	22,3	0,16							
1210	1210...	11	12	14	16	18	19	20	22	24	25	28	30	32	407	3/8" x 5/8"	47,5	1	25,4	0,32							
1215	1215...	14	19	20	24	25	28	407	3/8" x 5/8"	47,5	1	38,1	0,50														
1610	1610...	14	16	18	19	20	22	24	25	28	30	32	35	38	40*	42*	486	3/8" x 5/8"	57,0	1	25,4	0,41					
1615	1615...	14	16	18	19	20	22	24	25	28	30	32	35	38	40*	42*	486	3/8" x 5/8"	57,0	1	38,1	0,60					
2012	2012...	14	16	18	19	20	22	24	25	28	30	32	35	38	40	42	45	48	50	808	7/16" x 7/8"	70,0	1	31,8	0,75		
2517	2517...	16	18	19	20	22	24	25	28	30	32	35	38	40	42	45	48	50	55	60	65*	1310	1/2" x 1"	85,5	1	44,5	1,06
3020	3020...	25	28	30	32	35	38	40	42	45	48	50	55	60	65	70	75	2710	5/8" x 1" 1/4	108,0	1	50,8	2,50				
3030	3030...	35	38	40	42	45	48	50	55	60	65	70	75	2710	5/8" x 1" 1/2	108,0	1	76,2	3,75								
3525	3525...	35	38	40	42	45	48	50	55	60	65	70	75	80	5060	1/2" x 1" 1/2	127,0	2	64,9	4,20							
3535	3535...	35	38	40	42	45	48	50	55	60	65	70	75	80	85	90	5060	1/2" x 1" 1/2	127,0	2	88,9	5,13					
4030	4030...	40	42	45	48	50	55	60	65	70	75	80	85	90	100	8740	5/8" x 1" 1/2	146,0	2	76,2	6,75						
4040	4040...	40	42	45	48	50	55	60	65	70	75	80	85	90	100	8740	5/8" x 1" 3/4	146,0	2	101,6	7,68						
4545	4545...	55	60	65	70	75	80	85	90	100	12400	3/4" x 2"	162,0	2	115,0	10,56											
5050	5050...	70	75	80	85	90	100	105	110	115	120	125	14200	7/8" x 2" 1/4	177,6	2	127,0	15,17									

Wymiary wpustów (UNI 6604 DIN 6885) do standardowych kół

D	b	Js9	t		Wymiary wpustów							
					D*	b	t					
Over 10 to 12	4	±0,015	D + 1,8		28*	8	D + 1,3					
» 12 » 17	5		D + 2,3									
» 17 » 22	6		D + 2,8									
» 22 » 30	8	±0,015	D + 3,3									
» 30 » 38			10					D + 3,3				
» 38 » 44	12	±0,021	D + 3,3					40*/42*	12	D + 1,3		
» 44 » 50			14								D + 3,8	
» 50 » 58			16								D + 4,3	
» 58 » 65	18	D + 4,4	50*								14	D + 2,8
» 65 » 75	20	±0,026										
» 75 » 85				22	D + 5,4							
» 85 » 95	25	D + 5,4	65*	18	D + 2,8							
» 95 » 110	28	D + 6,4										
» 110 » 130	32	±0,031	D + 7,4	90*	25	D + 3,4						
				100*	28	D + 3,4						



ELEMENTY BLOKUJĄCE PIERŚCIEŃ ROZPRĘŻNO-ZACISKOWY



ELEMENTY BLOKUJĄCE PIERŚCIEŃ ROZPRĘŻNO-ZACISKKOWY

Seria KLAA/BK13/RCK13/203

Materiał C45 E - UNI EN 10083-1
Wymiary przed zamontowaniem

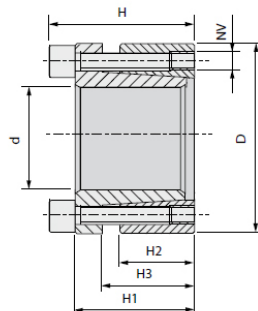

KOD	Wymiary						Siła Docisku			Odblokowywanie		Moment obrotowy			
	d	D	H3	H1	H	H2	NV typ śruby	Tv (Nm)	Śruby	NV typ śruby	Śruby	Mt (Nm)	Pa (N/mm ²)	T _a (kN)	Pm (N/mm ²)
KLAA019	19	47	22	28	34	17	M6x20	14	5	M6	3	355	280	31	120
KLAA020	20	47	22	28	34	17	M6x20	14	5	M6	3	360	280	33	120
KLAA022	22	47	22	28	34	17	M6x20	14	5	M6	3	400	268	33	123
KLAA024	24	50	22	28	34	17	M6x20	14	6	M6	3	440	243	36	120
KLAA025	25	50	22	28	34	17	M6x20	14	6	M6	3	560	280	36	138
KLAA028	28	55	22	28	34	17	M6x20	14	6	M6	3	625	250	36	128
KLAA030	30	55	22	28	34	17	M6x20	14	6	M6	3	650	235	36	128
KLAA032	32	60	22	28	34	17	M6x20	14	8	M6	4	950	290	50	150
KLAA035	35	60	22	28	34	17	M6x20	14	8	M6	4	1050	268	50	150
KLAA038	38	65	22	28	34	17	M6x20	14	8	M6	4	1140	252	50	146
KLAA040	40	65	22	28	34	17	M6x20	14	8	M6	4	1200	232	50	146
KLAA045	45	75	25	33	41	20	M8x25	35	7	M8	3	2180	285	70	168
KLAA050	50	80	25	33	41	20	M8x25	35	7	M8	3	2430	258	85	158
KLAA055	55	85	25	33	41	20	M8x25	35	8	M8	4	3050	268	85	173
KLAA060	60	90	25	33	41	20	M8x25	35	8	M8	4	3350	243	85	163
KLAA065	65	95	25	33	41	20	M8x25	35	9	M8	3	4080	253	85	173
KLAA070	70	110	30	40	50	24	M10x30	70	8	M10	4	6280	278	119	178
KLAA075	75	115	30	40	50	24	M10x30	70	8	M10	4	6680	258	119	168
KLAA080	80	120	30	40	50	24	M10x30	70	8	M10	4	7130	248	119	168
KLAA085	85	125	30	40	50	24	M10x30	70	9	M10	3	8750	258	132	178
KLAA090	90	130	30	40	50	24	M10x30	70	9	M10	3	9080	248	132	168
KLAA095	95	135	30	40	50	24	M10x30	70	10	M10	4	10580	258	132	178
KLAA100	100	145	32	44	56	26	M12x35	125	8	M12	4	13380	268	170	188
KLAA110	110	155	32	44	56	26	M12x35	125	8	M12	4	14580	238	170	178
KLAA120	120	165	32	44	56	26	M12x35	125	9	M12	4	17880	248	200	178
KLAA130	130	180	40	52	64	34	M12x35	190	12	M12	6	25950	238	270	168
KLAA140	140	190	40	54	68	34	M14x40	190	9	M14	4	26950	208	270	148
KLAA150	150	200	40	54	68	34	M14x40	190	10	M14	5	32950	228	320	168



ELEMENTY BLOKUJĄCE PIERŚCIEŃ ROZPRĘŻNO-ZACISKKOWY

Seria KLAB/BK16/RCK16/206

Materiał C45 E - UNI EN 10083-1
Wymiary przed zamontowaniem

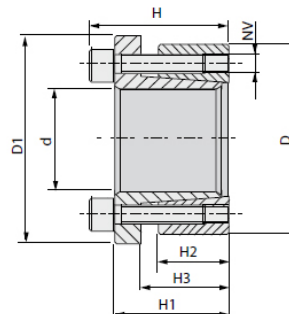

KOD	Wymiar							NV typ śruby	Tv (Nm)	Śruby	NV typ śruby	Śruby	Mt (Nm)	Pa (N/mm ²)	B (kN)	Pm (N/mm ²)
	d	D	D1	H	H1	H2	H3									
KLAB019	19	47	56	34	28	17	22	M6x20	17	5	M6	3	274	215	28	93
KLAB020	20	47	56	34	28	17	22	M6x20	17	5	M6	3	284	215	32	93
KLAB022	22	47	56	34	28	17	22	M6x20	17	5	M6	3	314	196	32	93
KLAB024	24	50	59	34	28	17	22	M6x20	17	6	M6	3	401	215	32	107
KLAB025	25	50	59	34	28	17	22	M6x20	17	6	M6	3	441	210	34	107
KLAB028	28	55	64	34	28	17	22	M6x20	17	6	M6	3	490	196	34	98
KLAB030	30	55	64	34	28	17	22	M6x20	17	6	M6	3	529	186	34	98
KLAB032	32	60	69	34	28	17	22	M6x20	17	8	M6	4	755	210	46	112
KLAB035	35	60	69	34	28	17	22	M6x20	17	8	M6	4	824	186	46	107
KLAB038	38	65	74	34	28	17	22	M6x20	17	8	M6	4	892	191	46	112
KLAB040	40	65	74	34	28	17	22	M6x20	17	8	M6	4	941	186	46	102
KLAB045	45	75	84	41	33	20	25	M8x25	41	7	M8	3	1716	225	64	132
KLAB050	50	80	89	41	33	20	25	M8x25	41	7	M8	3	1893	205	85	127
KLAB055	55	85	94	41	33	20	25	M8x25	41	8	M8	4	2403	210	85	132
KLAB060	60	90	99	41	33	20	25	M8x25	41	8	M8	4	2648	186	85	122
KLAB065	65	95	104	41	33	20	25	M8x25	41	9	M8	3	3188	196	85	132
KLAB070	70	110	119	50	40	24	30	M10x30	83	8	M10	4	4905	215	119	137
KLAB075	75	115	124	50	40	24	30	M10x30	83	8	M10	4	5150	195	119	127
KLAB080	80	120	129	50	40	24	30	M10x30	83	8	M10	4	5490	185	119	122
KLAB085	85	125	134	50	40	24	30	M10x30	83	9	M10	3	6620	195	132	132
KLAB090	90	130	139	50	40	24	30	M10x30	83	9	M10	3	6960	185	132	127
KLAB095	95	135	144	50	40	24	30	M10x30	83	10	M10	4	8190	195	132	137
KLAB100	100	145	154	56	44	26	32	M12x35	145	8	M12	4	10100	205	170	145
KLAB110	110	155	164	56	44	26	32	M12x35	145	8	M12	4	11030	190	170	135
KLAB120	120	165	174	56	44	26	32	M12x35	145	9	M12	4	13600	205	200	142
KLAB130	130	180	189	64	52	34	40	M12x35	145	12	M12	6	19000	186	270	137
KLAB140	140	190	199	68	54	34	40	M14x40	230	9	M14	4	21800	177	270	127
KLAB150	150	200	209	68	54	34	40	M14x40	230	10	M14	5	25600	185	320	137



ELEMENTY BLOKUJĄCE PIERŚCIEŃ ROZPRĘŻNO-ZACISKOWY

Seria KLBB/BK15/RCK15/256

Materiał C45 E - UNI EN 10083-1
Wymiary przed zamontowaniem

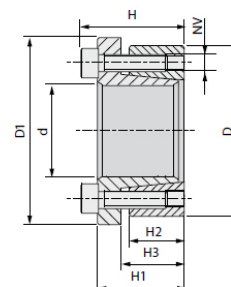

KOD	Wymiary							Siła Docisku			Odblokowywanie		Moment obrotowy			
	d	D	D1	H	H1	H2	H3	NV typ śruby	Tv (Nm)	Śruby	NV typ śruby	Śruby	Mt (Nm)	Pa (N/mm ²)	Ta (kN)	Pm (N/mm ²)
KLBB114	14	55	62	38	30	17	22	M8x25	42	4	M8	2	290	460	40	110
KLBB116	16	55	62	38	30	17	22	M8x25	42	4	M8	2	330	400	40	110
KLBB118	18	55	62	38	30	17	22	M8x25	42	4	M8	2	370	360	40	110
KLBB119	19	55	62	38	30	17	22	M8x25	42	4	M8	2	390	340	40	110
KLBB120	20	55	62	38	30	17	22	M8x25	42	4	M8	2	410	320	40	110
KLBB122	22	55	62	38	30	17	22	M8x25	42	4	M8	2	450	290	40	110
KLBB124	24	55	62	38	30	17	22	M8x25	42	4	M8	2	490	270	40	110
KLBB125	25	55	62	38	30	17	22	M8x25	42	4	M8	2	510	260	40	110
KLBB128	28	55	62	38	30	17	22	M8x25	42	4	M8	2	570	230	40	110
KLBB130	30	55	62	38	30	17	22	M8x25	42	4	M8	2	610	220	40	110
KLBB224	24	65	72	38	30	17	22	M8x25	42	5	M6	3	610	330	50	120
KLBB225	25	65	72	38	30	17	22	M8x25	42	5	M8	3	640	320	50	120
KLBB228	28	65	72	38	30	17	22	M8x25	42	5	M8	3	710	290	50	120
KLBB230	30	65	72	38	30	17	22	M8x25	42	5	M8	3	770	270	50	120
KLBB232	32	65	72	38	30	17	22	M8x25	42	5	M8	3	820	250	50	120
KLBB233	33	65	72	38	30	17	22	M8x25	42	5	M8	3	850	240	50	120
KLBB235	35	65	72	38	30	17	22	M8x25	42	5	M8	3	890	230	50	120
KLBB238	38	65	72	38	30	17	22	M8x25	42	5	M8	3	970	210	50	120
KLBB240	40	65	72	38	30	17	22	M8x25	42	5	M8	3	1020	200	50	120
KLBB330	30	80	87	41	33	20	25	M8x25	42	7	M8	3	1070	320	70	110
KLBB332	32	80	87	41	33	20	25	M8x25	42	7	M8	3	1140	300	70	110
KLBB333	33	80	87	41	33	20	25	M8x25	42	7	M8	3	1180	280	70	110
KLBB335	35	80	87	41	33	20	25	M8x25	42	7	M8	3	1250	270	60	110
KLBB338	38	80	87	41	33	20	25	M8x25	42	7	M8	3	1350	250	60	110
KLBB340	40	80	87	41	33	20	25	M8x25	42	7	M8	3	1420	240	70	110
KLBB342	42	80	87	41	33	20	25	M8x25	42	7	M8	3	1500	230	70	110
KLBB345	45	80	87	41	33	20	25	M8x25	42	7	M8	3	1600	210	60	110
KLBB348	48	80	87	41	33	20	25	M8x25	42	7	M8	3	1710	200	70	110
KLBB350	50	80	87	41	33	20	25	M8x25	42	7	M8	3	1780	190	60	110



ELEMENTY BLOKUJĄCE PIERŚCIEN ROZPRĘŻNO-ZACISKKOWY

Seria KLCC/BK80/RCK80/250

Materiał C45 E - UNI EN 10083-1
Wymiary przed zamontowaniem

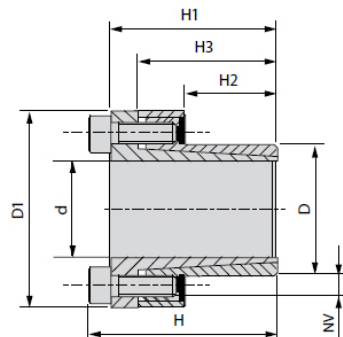

KOD	Wymiar								NV typ śruby	Tv (Nm)	Śruby	NV typ śruby	Śruby	Mt (Nm)	Pa (N/mm ²)	F _a (kN)	Pm (N/mm ²)
	d	D	D1	H	H1	H2	H3										
KLCC008	8	15	28	28	24	12	21	M4x12	5,2	4	M4	3	30	190	7,19	105	
KLCC009	9	16	32	31	27	14	23	M4x12	5,2	4	M4	3	32	150	7,19	92	
KLCC010	10	16	32	31	27	14	23	M4x12	5,2	4	M4	3	40	140	9	90	
KLCC011	11	18	34	31	27	14	23	M4x12	5,2	4	M4	3	50	175	9	107	
KLCC012	12	18	34	31	27	14	23	M4x12	5,2	4	M4	3	55	161	9	107	
KLCC014	14	23	39	31	27	14	23	M4x12	5,2	4	M4	3	64	137	9	84	
KLCC015	15	24	45	42	36	16	29	M6x18	17	3	M6	2	99	162	13	101	
KLCC016	16	24	45	42	36	16	29	M6x18	17	3	M6	2	105	152	13	101	
KLCC018	18	26	47	44	38	18	31	M6x18	17	4	M6	3	158	160	18	111	
KLCC019	19	27	48	44	38	18	31	M6x18	17	4	M6	3	167	151	18	107	
KLCC020	20	28	49	44	38	18	31	M6x18	17	4	M6	3	176	144	21	103	
KLCC022	22	32	54	51	45	25	38	M6x18	17	4	M6	3	232	113	21	78	
KLCC024	24	34	56	51	45	25	38	M6x18	17	4	M6	3	253	103	21	73	
KLCC025	25	34	56	51	45	25	38	M6x18	17	4	M6	3	263	99	21	73	
KLCC028	28	39	61	51	45	25	38	M6x18	17	5	M6	3	368	111	31	80	
KLCC030	30	41	63	51	45	25	38	M6x18	17	6	M6	3	474	124	31	91	
KLCC032	32	43	65	56	50	30	43	M6x18	17	6	M6	3	505	97	31	72	
KLCC035	35	47	69	56	50	30	43	M6x18	17	8	M6	4	737	119	42	88	
KLCC038	38	50	72	56	50	30	43	M6x18	17	8	M6	4	800	109	42	83	
KLCC040	40	53	75	58	52	32	45	M6x18	17	9	M6	4	947	109	53	82	
KLCC042	42	55	77	58	52	32	45	M6x18	42	9	M6	4	994	104	78	79	
KLCC045	45	59	85	72	64	40	56	M8x22	42	8	M8	4	1750	127	78	97	
KLCC048	48	62	88	72	64	40	56	M8x22	42	8	M8	4	1867	119	78	92	
KLCC050	50	65	92	82	74	50	66	M8x22	42	10	M8	5	2431	115	97	98	
KLCC055	55	71	98	82	74	50	66	M8x22	42	10	M8	5	2674	104	97	81	
KLCC060	60	77	104	82	74	50	66	M8x22	42	10	M8	5	2917	96	97	74	
KLCC065	65	84	111	82	74	50	66	M8x22	42	10	M8	5	3160	88	97	69	
KLCC070	70	90	122	101	91	60	80	M10x25	84	8	M10	4	4322	87	123	67	
KLCC075	75	95	126	101	91	60	80	M10x25	84	9	M10	4	6171	93	197	74	
KLCC080	80	100	131	106	96	65	85	M10x25	84	12	M10	5	7899	97	237	77	
KLCC085	85	106	137	106	96	65	85	M10x25	84	12	M10	5	8393	91	237	73	
KLCC090	90	112	143	106	96	65	85	M10x25	84	14	M10	6	10367	100	276	51	
KLCC095	95	120	153	106	96	65	85	M10x25	84	14	M10	6	10943	95	276	75	
KLCC100	100	125	162	114	102	65	89	M12x30	145	12	M12	5	14520	114	348	91	
KLCC110	110	140	177	119	107	70	94	M12x30	145	12	M12	5	15972	96	348	75	
KLCC120	120	155	195	139	127	90	114	M12x30	145	16	M12	7	23232	91	465	71	
KLCC130	130	165	205	139	127	90	114	M12x30	145	16	M12	7	25168	84	465	66	
KLCC140	140	175	215	139	127	90	114	M12x30	145	16	M12	7	27104	78	465	63	
KLCC150	150	185	225	139	127	90	114	M12x30	145	16	M12	7	29041	73	465	59	



ELEMENTY BLOKUJĄCE PIERŚCIEŃ ROZPRĘŻNO-ZACISKKOWY

Seria KLDA/BK70/RCK70/200

Materiał C45 E - UNI EN 10083-1
Wymiary przed zamontowaniem

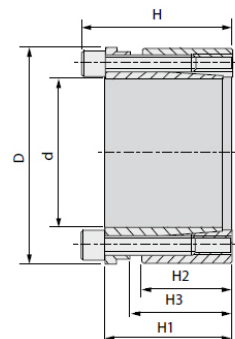

KOD	Wymiary						Siła Docisku			Odblokowywanie		Moment obrotowy			
	d	D	H	H1	H2	H3	NV typ śruby	Tv (Nm)	Śruby	NV typ śruby	Śruby	Mt (Nm)	Pa (N/mm ²)	Ta (kN)	Pm (N/mm ²)
KLDA019	19	47	45	39	26	31	M6x25	17	4	M6	2	353	228	30,6	98
KLDA020	20	47	45	39	26	31	M6x25	17	4	M6	2	382	226	33,4	98
KLDA022	22	47	45	39	26	31	M6x25	17	4	M6	2	431	215	33,4	93
KLDA024	24	50	45	39	26	31	M6x25	17	6	M6	3	519	215	50,2	102
KLDA025	25	50	45	39	26	31	M6x25	17	6	M6	3	578	225	50,2	102
KLDA028	28	55	45	39	26	31	M6x25	17	6	M6	3	686	215	50,2	107
KLDA030	30	55	45	39	26	31	M6x25	17	6	M6	3	745	196	50,2	117
KLDA032	32	60	45	39	26	31	M6x25	17	8	M6	4	912	225	66,9	111
KLDA035	35	60	45	39	26	31	M6x25	17	8	M6	4	1010	196	66,9	116
KLDA038	38	65	45	39	26	31	M6x25	17	8	M6	4	1216	205	66,9	121
KLDA040	40	65	45	39	26	31	M6x25	17	8	M6	4	1323	196	66,9	122
KLDA042	42	75	55	47	30	36	M8x30	41	6	M8	3	2128	232	66,9	137
KLDA045	45	75	55	47	30	36	M8x30	41	6	M8	3	2304	232	92,1	137
KLDA048	48	80	55	47	30	36	M8x30	41	6	M8	3	2461	213	110,0	132
KLDA050	50	80	55	47	30	36	M8x30	41	6	M8	3	2530	213	122,8	132
KLDA055	55	85	55	47	30	36	M8x30	41	8	M8	4	3138	218	122,8	142
KLDA060	60	90	55	47	30	36	M8x30	41	8	M8	4	3314	194	122,8	153
KLDA065	65	95	55	47	30	36	M8x30	41	8	M8	4	4079	208	122,8	137
KLDA070	70	110	67	57	40	46	M10x35	83	8	M10	4	6707	220	193,5	140
KLDA075	75	115	72	62	40	46	M10x35	83	8	M10	4	7354	205	193,5	135
KLDA080	80	120	72	62	40	46	M10x35	83	8	M10	4	7943	196	193,5	127
KLDA085	85	125	72	62	40	46	M10x35	83	10	M10	4	9512	205	241,9	142
KLDA090	90	130	72	62	40	46	M10x35	83	10	M10	4	10100	196	241,9	135
KLDA095	95	135	72	62	40	46	M10x35	83	10	M10	4	11865	205	241,9	145
KLDA100	100	145	89	77	46	52	M12x45	145	8	M12	4	15396	211	282,8	145
KLDA110	110	155	89	77	46	52	M12x45	145	8	M12	4	16867	192	282,8	136
KLDA120	120	165	89	77	46	52	M12x45	145	10	M12	4	22064	211	353,6	152
KLDA130	130	180	89	77	46	52	M12x45	145	12	M12	4	23535	192	424,3	137
KLDA140	140	190	98	84	51	59	M14x45	230	8	M14	4	30210	192	448,5	142
KLDA150	150	200	98	84	51	59	M14x45	230	10	M14	5	36440	201	489,0	150



ELEMENTY BLOKUJĄCE PIERŚCIEŃ ROZPRĘŻNO-ZACISKKOWY

Seria KLDB/BK71/RCK71/201

Materiał C45 E - UNI EN 10083-1
Wymiary przed zamontowaniem

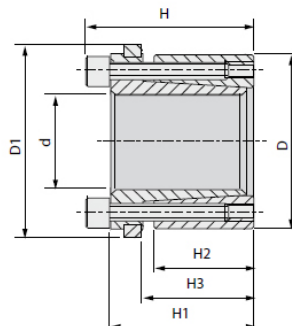

KOD	Wymiar								NV typ śruby	Tv (Nm)	Śruby	NV typ śruby	Śruby	Mt (Nm)	Pa (N/mm ²)	\bar{F} (kN)	Pm (N/mm ²)
	d	D	D1	H	H1	H2	H3	H4									
KLDB019	19	47	53	45	39	26	31	M6x25	17	4	M6	2	294	228	198	96	
KLDB020	20	47	53	45	39	26	31	M6x25	17	4	M6	2	313	226	234	96	
KLDB022	22	47	53	45	39	26	31	M6x25	17	4	M6	2	362	206	234	97	
KLDB024	24	50	56	45	39	26	31	M6x25	17	6	M6	3	421	206	351	100	
KLDB025	25	50	56	45	39	26	31	M6x25	17	6	M6	3	470	221	351	110	
KLDB028	28	55	61	45	39	26	31	M6x25	17	6	M6	3	578	202	351	105	
KLDB030	30	55	61	45	39	26	31	M6x25	17	6	M6	3	637	221	351	118	
KLDB032	32	60	66	45	39	26	31	M6x25	17	8	M6	4	784	197	468	114	
KLDB035	35	60	66	45	39	26	31	M6x25	17	8	M6	4	843	202	468	118	
KLDB038	38	65	71	45	39	26	31	M6x25	17	8	M6	4	1010	197	468	121	
KLDB040	40	65	71	45	39	26	31	M6x25	17	8	M6	4	1108	234	468	143	
KLDB042	42	75	81	55	47	30	36	M8x30	41	6	M8	3	1892	216	468	135	
KLDB045	45	75	81	55	47	30	36	M8x30	41	6	M8	3	1912	216	644	135	
KLDB048	48	80	86	55	47	30	36	M8x30	41	6	M8	3	2137	221	736	142	
KLDB050	50	80	86	55	47	30	36	M8x30	41	6	M8	3	2167	221	86	143	
KLDB055	55	85	91	55	47	30	36	M8x30	41	8	M8	4	2677	221	86	143	
KLDB060	60	90	96	55	47	30	36	M8x30	41	8	M8	4	2853	197	86	131	
KLDB065	65	95	101	55	47	30	36	M8x30	41	8	M8	4	3500	206	86	142	
KLDB070	70	110	116	67	57	40	46	M10x35	83	8	M10	4	5717	221	135	142	
KLDB075	75	115	121	72	62	40	46	M10x35	83	8	M10	4	6207	216	135	148	
KLDB080	80	120	126	72	62	40	46	M10x35	83	8	M10	4	6707	198	135	139	
KLDB085	85	125	131	72	62	40	46	M10x35	83	10	M10	4	8002	216	169	157	
KLDB090	90	130	136	72	62	40	46	M10x35	83	10	M10	4	8502	197	169	143	
KLDB095	95	135	141	72	62	40	46	M10x35	83	10	M10	4	10002	187	169	138	
KLDB100	100	145	151	89	77	46	52	M12x45	145	8	M12	4	13336	197	198	148	
KLDB110	110	155	161	89	77	46	52	M12x45	145	8	M12	4	14582	197	198	178	
KLDB120	120	165	171	89	77	46	52	M12x45	145	10	M12	4	19083	216	248	158	
KLDB130	130	180	186	89	77	46	52	M12x45	145	12	M12	4	20417	198	297	143	
KLDB140	140	190	196	98	84	51	59	M12x45	230	8	M14	4	24920	188	342	138	
KLDB150	150	200	206	98	84	51	59	M12x45	230	10	M14	5	30130	198	342	149	



ELEMENTY BLOKUJĄCE PIERŚCIEN ROZPRĘŻNO-ZACISKOWY

Seria KLEE/BK11/RCK11/400

Materiał C45 E - UNI EN 10083-1
Wymiary przed zamontowaniem

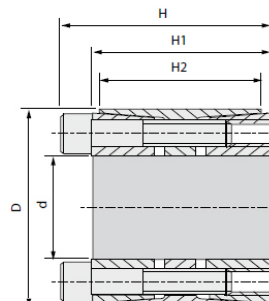

KOD	Wymiary					Siła Docisku			Odblokowywanie		Moment obrotowy			
	d	D	H	H1	H2	NV typ śruby	Tv (Nm)	Śruby	NV typ śruby	Śruby	Mt (Nm)	Pa (N/mm ²)	Ta (kN)	Pm (N/mm ²)
KLEE025	25	55	46	40	32	M6 x 35	17,5	6	M6	3	750	250	70	130
KLEE028	28	55	46	40	32	M6 x 35	17,5	6	M6	3	830	220	70	120
KLEE030	30	55	46	40	32	M6 x 35	17,5	6	M6	3	890	210	70	120
KLEE035	35	60	60	54	44	M6 x 45	17,5	7	M6	3	1220	150	80	90
KLEE038	38	75	62	54	44	M8 x 50	42	7	M8	3	2270	240	130	120
KLEE040	40	75	62	54	44	M8 x 50	42	7	M8	3	2390	230	130	140
KLEE042	42	75	62	54	44	M8 x 50	42	7	M8	3	2510	220	130	120
KLEE045	45	75	62	54	44	M8 x 50	42	7	M8	3	2690	200	130	120
KLEE048	48	80	72	64	56	M8 x 55	42	8	M8	4	3270	220	150	130
KLEE050	50	80	72	64	56	M8 x 55	42	8	M8	4	3410	170	150	110
KLEE055	55	85	72	64	56	M8 x 55	42	9	M8	4	4220	170	170	110
KLEE060	60	90	72	64	56	M8 x 55	42	10	M8	4	5110	170	180	120
KLEE065	65	95	72	64	56	M8 x 55	42	10	M8	4	5540	160	190	110
KLEE070	70	110	88	78	70	M10 x 60	85	10	M10	4	10150	200	310	130
KLEE075	75	115	88	78	70	M10 x 60	85	10	M10	4	10870	190	320	120
KLEE080	80	120	88	78	70	M10 x 60	85	11	M10	4	12760	190	340	130
KLEE085	85	125	88	78	70	M10 x 60	85	12	M10	5	14790	200	380	140
KLEE090	90	130	88	78	70	M10 x 60	85	12	M10	5	15660	190	380	130
KLEE095	95	135	88	78	70	M10 x 60	85	12	M10	5	16530	180	380	130
KLEE100	100	145	112	100	90	M12 x 80	145	12	M12	4	23250	180	510	120
KLEE110	110	155	112	100	90	M12 x 80	145	12	M12	5	27900	170	530	130
KLEE120	120	165	112	100	90	M12 x 80	145	14	M12	6	35510	190	650	140
KLEE130	130	180	130	116	104	M14 x 90	235	12	M14	5	45130	180	770	130
KLEE140	140	190	130	116	104	M14 x 90	235	14	M14	7	56700	190	870	140
KLEE150	150	200	130	116	104	M14 x 90	235	15	M14	7	65090	190	940	140
KLEE160	160	210	130	116	104	M14 x 90	235	16	M14	7	74060	190	1000	150
KLEE170	170	225	164	148	134	M16 x 120	360	14	M16	7	95240	170	1220	130
KLEE180	180	235	164	148	134	M16 x 120	360	16	M16	7	108050	170	1290	130
KLEE190	190	250	164	148	134	M16 x 120	360	16	M16	7	121650	170	1360	130
KLEE200	200	260	164	148	134	M16 x 120	360	16	M16	7	128060	160	1350	130
KLEE220	220	285	164	148	134	M16 x 120	360	18	M16	8	158470	170	1580	130



ELEMENTY BLOKUJĄCE PIERŚCIEŃ ROZPRĘŻNO-ZACISKKOWY

Seria KLFF/BK55/RCK55/125 KLFC/BK55/RCK55/125

Materiał C45 E - UNI EN 10083-1

Wymiary przed zamontowaniem

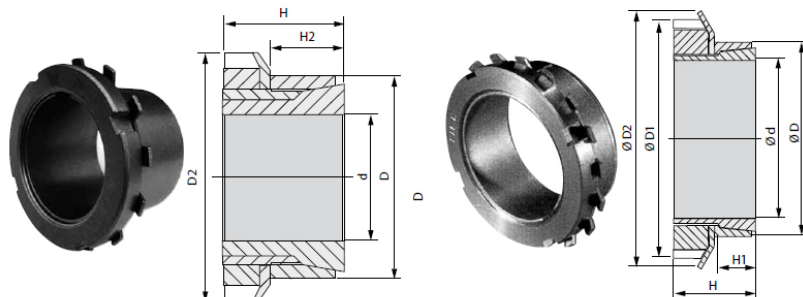

KOD	Wymiary						Siła Docisku		Moment obrotowy			
	d	D	D1	H	H2	H3	NV typ śruby	Tv (Nm)	Mt (Nm)	Pa (N/mm ²)	Ta (kN)	Pm (Nmm ²)
KLFF015	15	25	32	31	23	34	M20 x 1	95	70	80	9	45
KLFF018	18	30	38	32,9	24	41	M25x1,5	160	100	75	13	45
KLFF019	19	30	38	32,9	24	41	M25x1,5	160	105	75	13	45
KLFF020	20	30	38	32,9	24	41	M25x1,5	160	112	70	13	45
KLFF024	24	35	45	32,9	29	48	M30x1,5	220	178	65	15	45
KLFF025	25	35	45	32,9	29	48	M30x1,5	220	185	60	15	45
KLFF028	28	40	52	43,9	34	55	M35x1,5	340	250	55	20	40
KLFF030	30	40	52	43,9	34	55	M35x1,5	340	270	50	20	40
KLFF035	35	45	58	44,9	34	61	M40x1,5	480	390	55	25	45
KLFF040	40	50	65	45,9	35	67	M45x1,5	680	520	55	31	45
KLFF045	45	55	70	46,9	35	73	M50x1,5	870	680	60	36	50
KLFF050	50	60	75	46,9	36	81	M55x2	970	880	60	37	50
KLFF055	55	65	80	47,9	36	87	M60x2	1100	1030	60	38	50
KLFF060	60	70	85	49,9	36	93	M65x2	1300	1360	65	41	55

KOD	Wymiary						Siła Docisku		Moment obrotowy			
	d	D	D1	H	H2	H3	NV typ śruby	Tv (Nm)	Mt (Nm)	Pa (N/mm ²)	Ta (kN)	Pm (Nmm ²)
KLFC014	14	25	32	17	6,5	34	M20 x 1	95	52	241	7	135
KLFC015	15	25	32	17	6,5	34	M20 x 1	95	56	225	7	135
KLFC016	16	25	32	17	6,5	34	M20 x 1	95	60	211	7	135
KLFC018	18	30	38	17,5	6,5	41	M25x1,5	160	91	256	10	154
KLFC019	19	30	38	18	6,5	41	M25x1,5	160	96	242	10	154
KLFC020	20	30	38	18	6,5	41	M25x1,5	160	102	230	10	154
KLFC024	24	35	45	18	6,5	48	M30x1,5	220	139	218	12	150
KLFC025	25	35	45	18	6,5	48	M30x1,5	220	144	210	12	150
KLFC028	28	40	52	18	6,5	55	M35x1,5	340	215	248	15	174
KLFC030	30	40	52	20	8	55	M35x1,5	340	230	188	15	141
KLFC035	35	45	58	22	8	61	M40x1,5	480	331	199	19	155
KLFC040	40	50	65	25	10	67	M45x1,5	680	477	176	24	141
KLFC045	45	55	70	26	10	73	M50x1,5	870	617	180	27	147
KLFC048	48	60	75	26	10	81	M55x2	970	669	171	28	137
KLFC050	50	60	75	26	10	81	M55x2	970	697	164	28	137
KLFC055	55	65	80	27	12	87	M60x2	1100	796	129	29	109
KLFC060	60	70	85	29	12	93	M65x2	1300	946	129	32	111
KLFC070	70	84	98	31,5	13,5	104	M75x2	2000	1433	128	41	106



ELEMENTY BLOKUJĄCE PIERŚCIEŃ ROZPRĘŻNO-ZACISKKOWY

Seria KLGG/BK40/RCK40/100

Materiał C45 E - UNI EN 10083-1
Wymiary przed zamontowaniem

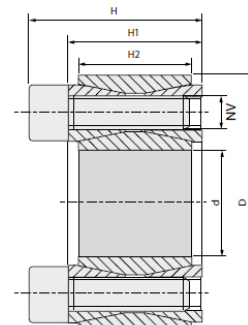

KOD	Wymiary					Siła Docisku			Odblokowywanie		Moment obrotowy			
	d	D	H	H1	H2	NV typ śruby	Tv (Nm)	Śruby	NV typ śruby	Śruby	Mt (Nm)	Pa (N/mm ²)	Ta (kN)	Pm (N/mm ²)
KLGG019	19	47	26	20	17	M6 x 18	16	8	M8	2	260	220	26,8	93
KLGG020	20	47	26	20	17	M6 x 18	16	8	M8	2	268	210	26,8	93
KLGG022	22	47	26	20	17	M6 x 18	16	8	M8	2	283	207	26,8	96
KLGG024	24	50	26	20	17	M6 x 18	16	9	M8	3	361	206	30,1	103
KLGG025	25	50	26	20	17	M6 x 18	16	9	M8	3	376	206	30,1	103
KLGG028	28	55	26	20	17	M6 x 18	16	10	M8	3	420	204	33,5	103
KLGG030	30	55	26	20	17	M6 x 18	16	10	M8	3	450	190	33,5	103
KLGG032	32	60	26	20	17	M6 x 18	16	12	M8	4	643	214	40,2	114
KLGG035	35	60	26	20	17	M6 x 18	16	12	M8	4	703	196	40,2	114
KLGG038	38	65	26	20	17	M6 x 18	16	14	M8	4	891	204	46,9	122
KLGG040	40	65	26	20	17	M6 x 18	16	14	M8	4	938	200	46,9	122
KLGG042	42	75	32	24	20	M8 x 22	38	12	M10	4	1537	228	73,2	125
KLGG045	45	75	32	24	20	M8 x 22	38	12	M10	4	1647	208	73,2	125
KLGG048	48	80	32	24	20	M8 x 22	38	12	M10	4	1756	190	73,2	110
KLGG050	50	80	32	24	20	M8 x 22	38	12	M10	4	1830	189	73,2	115
KLGG055	55	85	32	24	20	M8 x 22	38	14	M10	4	2348	200	85,4	130
KLGG060	60	90	32	24	20	M8 x 22	38	14	M10	4	2560	180	85,4	122
KLGG065	65	95	32	24	20	M8 x 22	38	16	M10	4	3170	191	97,6	130
KLGG070	70	110	38	28	24	M10 x 25	75	14	M12	4	4700	211	134,4	132
KLGG075	75	115	38	28	24	M10 x 25	75	14	M12	4	5000	194	134,4	128
KLGG080	80	120	38	28	24	M10 x 25	75	14	M12	4	5300	182	134,4	124
KLGG085	85	125	38	28	24	M10 x 25	75	16	M12	4	6500	196	153,6	133
KLGG090	90	130	38	28	24	M10 x 25	75	16	M12	4	6900	181	153,6	128
KLGG095	95	135	38	28	24	M10 x 25	75	18	M12	4	8200	196	172,8	139
KLGG100	100	145	45	33	26	M12 x 35	130	14	M14	4	9870	196	197,4	139
KLGG110	110	155	45	33	26	M12 x 35	130	14	M14	4	10800	181	187,4	128
KLGG120	120	165	45	33	26	M12 x 35	130	16	M14	4	13500	187	225,6	139
KLGG130	130	180	50	40	34	M12 x 35	130	20	M14	4	18300	168	282	119
KLGG140	140	190	50	40	34	M12 x 35	130	22	M14	4	21700	168	310,1	128
KLGG150	150	200	50	40	34	M12 x 35	130	24	M14	4	25300	170	338,4	128
KLGG160	160	210	50	40	34	M12 x 35	130	26	M14	4	29300	171	366,6	132
KLGG170	170	225	58	44	38	M14 x 40	207	22	M16	4	33000	162	389	123
KLGG180	180	235	58	44	38	M14 x 40	207	24	M16	4	38000	168	424	128
KLGG190	190	250	66	52	46	M14 x 45	207	28	M16	4	47000	154	495	114
KLGG200	200	260	66	52	46	M14 x 45	207	30	M16	4	53000	157	531	118



ELEMENTY BLOKUJĄCE PIERŚCIEŃ ROZPRĘŻNO-ZACISKKOWY

Seria KLHH/BK45/RCK45/90

Materiał C45 E - UNI EN 10083-1
Wymiary przed zamontowaniem

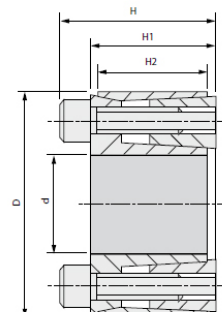

KOD	Wymiary					Siła Docisku			Odblokowywanie		Moment obrotowy			
	d	D	H	H1	H2	NV typ śruby	Tv (Nm)	Śruby	NV typ śruby	Śruby	Mt (Nm)	Pa (N/mm ²)	Ta (kN)	Pm (N/mm ²)
KLHH018	18	40	24	18,5	14,7	M6 x 16	17,5	4	M6	2	200	260		120
KLHH019	19	41	24	18	14,7	M6 x 16	17,5	4	M6	2	210	260		120
KLHH020	20	42	24	18	14,7	M6 x 16	17,5	4	M6	2	240	250		120
KLHH024	24	46	24	18	14,7	M6 x 16	17,5	6	M6	3	290	250		120
KLHH025	25	47	24	18	14,7	M6 x 16	17,5	6	M6	3	330	230		120
KLHH028	28	50	24	18	14,7	M6 x 16	17,5	6	M6	3	370	220		120
KLHH030	30	52	24	18	14,7	M6 x 16	17,5	6	M6	3	430	210		120
KLHH035	35	57	27,5	21,5	18	M6 x 18	17,5	6	M6	3	610	170		100
KLHH038	38	60	27,5	21,5	18	M6 x 18	17,5	8	M6	4	380	170		100
KLHH040	40	62	27,5	21,5	18	M6 x 18	17,5	8	M6	4	780	170		100
KLHH042	42	70	36	28	23,5	M8 x 25	42	8	M8	4	1480	190		110
KLHH045	45	73	36	28	23,5	M8 x 25	42	8	M8	4	1500	210		130
KLHH048	48	76	36	28	23,5	M8 x 25	42	8	M8	4	1550	210		130
KLHH050	50	78	36	28	23,5	M8 x 25	42	8	M8	4	1650	190		120
KLHH055	55	83	36	28	23,5	M8 x 25	42	8	M8	4	2000	190		120
KLHH060	60	88	36	28	23,5	M8 x 25	42	8	M8	4	2350	190		120
KLHH070	70	105	45	35	30	M10 x 40	42	8	M10	4	3900	180		120
KLHH080	80	115	45	35	30	M10 x 40	85	8	M10	4	4800	170		120



ELEMENTY BLOKUJĄCE PIERŚCIEŃ ROZPRĘŻNO-ZACISKOWY

Seria KLMM/BK95/RCK95/700

Materiał C45 E - UNI EN 10083-1
Wymiary przed zamontowaniem

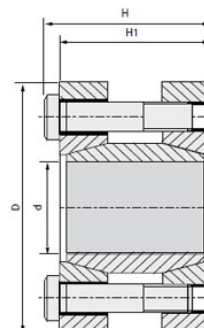

KOD	Wymiary										
	d	D	H1	H	NV typ śruby	Tv (Nm)	Śruby	Mt (Nm)	Pa (N/mm ²)	Ta (kN)	Pm (N/mm ²)
KLMM017	17	50	50	56	M6 x 45	17,5	4	200	110		
KLMM018	18	50	50	56	M6 x 45	17,5	4	220	110		
KLMM019	19	50	50	56	M6 x 45	17,5	4	230	110		
KLMM020	20	50	50	56	M6 x 45	17,5	4	240	105		
KLMM024	24	55	60	66	M6 x 55	17,5	6	290	120		
KLMM025	25	55	60	66	M6 x 55	17,5	6	450	110		
KLMM028	28	60	60	66	M6 x 55	17,5	6	510	110		
KLMM030	30	60	60	66	M6 x 55	17,5	6	550	105		
KLMM032	32	63	60	66	M6 x 55	17,5	6	580	90		
KLMM035	35	75	75	83	M8 x 70	42	4	790	105		
KLMM038	38	75	75	83	M8 x 70	42	4	850	100		
KLMM040	40	75	75	83	M8 x 70	42	4	900	95		
KLMM042	42	78	75	83	M8 x 70	42	4	950	90		
KLMM045	45	85	85	93	M8 x 80	42	6	1520	110		
KLMM048	48	90	85	93	M8 x 80	42	6	1620	100		
KLMM050	50	90	85	93	M8 x 80	42	6	1690	95		
KLMM055	55	94	85	93	M8 x 80	42	8	2470	110		
KLMM060	60	100	85	93	M8 x 80	42	8	2710	95		
KLMM065	65	105	85	93	M8 x 80	42	8	2930	90		
KLMM070	70	115	100	110	M10 x 95	85	8	3770	90		



ELEMENTY BLOKUJĄCE PIERŚCIEŃ ROZPRĘŻNO-ZACISKKOWY

Seria KLNN/BK50/RCK50/150

Materiał C45 E - UNI EN 10083-1
Wymiary przed zamontowaniem

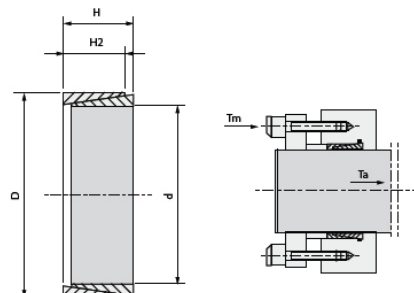

KOD	Wymiary					Siła Docisku			Moment obrotowy				
	d	D	D1	H	H2	NV yp śruby	Tv (Nm)	Śruby	Ta (kN)	Tm (Nm)	Mt (Nm)	Pa (N/mm ²)	Pm (N/mm ²)
KLNN008	8	11		4,5	3,7				1,09	9,1	4,3	98	72
KLNN009	9	12		4,5	3,7				1,22	9,1	5,5	98	73
KLNN010	10	13		4,5	3,7				1,37	12,1	6,9	98	75
KLNN012	12	15		4,5	3,7				1,64	12,4	9,8	98	78
KLNN014	14	18		6,3	5,3				2,74	20,4	19,2	98	76
KLNN015	15	19		6,3	5,3				2,94	23,5	22,1	98	77
KLNN016	16	20		6,3	5,3				3,14	23,9	25,1	98	78
KLNN018	18	22		6,3	5,3				3,53	24,8	31,8	98	80
KLNN019	19	24		6,3	5,3				3,72	29,1	35,3	98	77
KLNN020	20	25		6,3	5,3				3,92	29,5	39,2	98	78
KLNN022	22	26		6,3	5,3				4,31	28,3	47	98	83
KLNN024	24	28		6,3	5,3				4,7	29,4	56,8	98	84
KLNN025	25	30		6,3	5,3				4,9	31,8	60,8	98	81
KLNN028	28	32		6,3	5,3				5,49	31,9	76,4	98	86
KLNN030	30	35		6,3	5,3				5,88	34,8	88,2	98	84
KLNN032	32	36		6,3	5,3				6,27	35,9	100	98	87
KLNN035	35	40		7	6,0				7,74	44,8	136	98	86
KLNN038	38	44		7	6,0				8,43	48,8	160	98	84
KLNN040	40	45		8	6,6				9,75	57,6	195	98	87
KLNN042	42	48		8	6,6				10,3	61,4	216	98	86
KLNN045	45	52		10	8,6				14,3	90,3	321	98	85
KLNN048	48	55		10	8,6				15,3	92,7	367	98	85
KLNN050	50	57		10	8,6				15,9	94,7	397	98	86
KLNN055	55	62		10	8,6				17,4	99,7	480	98	87
KLNN060	60	68		12	10,4				23	130,9	692	98	86
KLNN065	65	73		12	10,4				25	134,9	813	98	87
KLNN070	70	79		14	12,2				31,6	172,4	1110	98	87
KLNN075	75	84		14	12,2				33,8	185,7	1260	98	87
KLNN080	80	91		17	15,0				44,1	247,1	1770	98	86
KLNN090	90	101		17	15,0				50	266,2	2240	98	87
KLNN100	100	114		21	18,7				69,6	370,8	3450	98	86



ELEMENTY BLOKUJĄCE PIERŚCIEŃ ROZPRĘŻNO-ZACISKKOWY

Seria KLPP/RCK19/BK19/603

Materiał C45 E - UNI EN 10083-1
Wymiary przed zamontowaniem

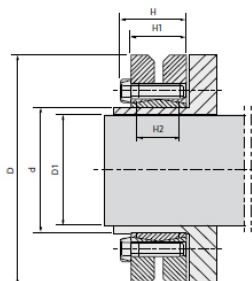

KOD	Wymiary						Siła Docisku			Moment obrotowy		
	d	D	D1	H	H1	H2	NV typ śruby	Tv (Nm)	Śruby	Mt (Nm)	Pa (N/mm ²)	Ta (kN)
KLPP024	24	50	19 20 21	23	19,5	14	M5 x 18	4,9	6	170 210 250	286	15,0 18,5 21,0
KLPP030	30	60	24 25 26	25	21,5	16	M5 x 18	4,9	7	300 340 380	233	15,7 23,7 26,7
KLPP036	36	72	28 30 31	27,5	23,5	18	M6 x 20	11,8	5	440 570 630	307	27,0 38,0 43,0
KLPP044	44	80	34 35 36	29,5	25,5	20	M6 x 20	11,8	7	620 780 860	317	44,0 49,0 54,0
KLPP050	50	90	38 40 42	31,5	27,5	22	M6 x 25	11,8	8	940 1160 1380	289	48,8 58,8 69,0
KLPP055	55	100	42 45 48	34,5	30,5	23	M6 x 25	11,8	8	1160 1520 1880	252	48,0 61,7 77,0
KLPP062	62	110	48 50 52	34,5	30,5	23	M6 x 25	11,8	10	1850 2200 2400	279	69,0 80,9 90,0
KLPP068	68	115	50 55 60	34,5	30,5	23	M6 x 25	11,8	10	2000 2500 3150	255	71,2 80,9 95,7
KLPP075	75	138	55 60 65	37,8	32,5	25	M8 x 30	29,4	7	2500 3200 3950	273	94,4 111,0 126,0
KLPP080	80	145	60 65 70	37,8	32,5	25	M8 x 30	29,4	7	3200 3900 4600	256	99,3 115,0 130,0
KLPP090	90	155	65 70 75	44,3	39	30	M8 x 35	29,4	10	4750 6000 7250	271	141,0 160,0 178,0
KLPP100	100	170	70 75 80	49,3	44	34	M8 x 35	29,4	12	6900 7500 9000	258	163,0 182,0 202,0
KLPP110	110	185	75 80 85	56,4	50	39	M10 x 40	57,8	9	7200 9000 10800	244	185,0 207,0 221,0
KLPP125	125	215	85 90 95	60,4	54	42	M10 x 40	57,8	12	11000 13000 15000	266	240,0 262,0 285,0
KLPP140	140	230	95 100 105	68	60,5	46	M12 x 45	98	10	15100 17600 20100	264	308,0 331,0 357,0
KLPP155	155	265	105 110 115	72	64,5	50	M12 x 50	98	12	22000 25000 28000	263	366,0 392,0 417,0
KLPP165	165	290	115 120 125	81	71	56	M16 x 55	245	8	31000 35000 39000	277	513,0 544,0 564,0

